



**INTERNATIONAL JOURNAL OF ENGINEERING SCIENCES & RESEARCH  
TECHNOLOGY**

**ANALYSIS OF IG BASED WIND FARM WITH STATCOM AND SVC IN MATLAB /  
SIMULINK**

**Sharmila\*, Pardeep Nain**

\* M.Tech Scholar, Department of EE, OITM, Hisar, India.  
Assistant Professor, Department of EE, OITM, Hisar, India.

---

**ABSTRACT**

When wind farm is connected to a grid system some issues of voltage stability and reactive power posed . The study includes the implementation of FACTS devices as voltage restorer to maintain stable voltage and thereby protection IG-based wind farm interconnected power system from isolating during and after disturbances. This analysis the application of FACTS devices in wind farm using squirrel cage induction generator. FACTS devices are used to enhance the voltage stability of wind farm using squirrel cage induction generator. FACTS devices used in the thesis are STATCOM and SVC . A comparison between these FACTS devices also done which is shown in results .When Wind farm is connected to a grid then problem of voltage dip occur due to variation in loads or other disturbances and this can be maintained to rated value using FACTS devices .A simulation model of 9MW wind farm interconnected to grid is carried out using the MATLAB Sim Power System Toolbox.

**KEYWORDS:** WINDFARM,STATCOM,FACTS,INDUCTION GENERATOR, SVC.

---

**INTRODUCTION**

Electrical power is most widely used source of energy for industries, homes, work place. Electricity generation by means of non renewable sources (coal, oil, gas) causes enhanced green house effect, leading to the warming of the earth' atmosphere. The adverse effect of conventional systems have given rise to a shift in focus toward renewable energy sources such as hydro, wind, tidal wave, biomass, and so on.

Global wind power installations increased by 35,467 megawatts (MW) and 51,447 MW in 2013 and 2014, respectively. As of the end of 2014, worldwide, total cumulative installed capacity from wind power amounts to 369,553 MW and increased by 16% compared to the previous year (318,106 MW). The development of wind power in India began in the 1990s, and has significantly increased in the last few years. Flexible AC Transmission Systems (FACTS) such as the Static Synchronous Compensator (STATCOM) and Static VAR compensation (SVC) are being used extensively in power systems because of their ability to provide flexible power flow control. The main motivation for choosing STATCOM and SVC for the voltage stability issue for IG –based wind farm connected to a grid and load . The applicability of a STATCOM in wind farms has been investigated and the results from early studies indicate that it is able to supply reactive power requirements of the wind farm under various operating conditions, thereby improving the steady-state stability limit of the network [6]. Transient and short-term generator stability conditions can also be improved

when a STATCOM has been introduced into the system as an active voltage/VAR supporter. This paper explores the possibility of enabling wind farms to provide voltage support during normal conditions, as well as under conditions when system voltages are not within desired limits. The transient behavior of wind farms can be improved by injecting large amounts of reactive power during fault recovery [10]. This paper examines the use of STATCOMs in wind farms to stabilize the grid voltage after grid disturbances such as line outages or severe system faults. The simulation studies have been carried out by using commercial simulation software such as a Matlab/ Simulink .The induction generator used in this thesis is squirrel cage induction generator that is fixed speed wind turbine.

**OUTLINES OF FACTS DEVICES SVC V-I CHARACTERISTICS**

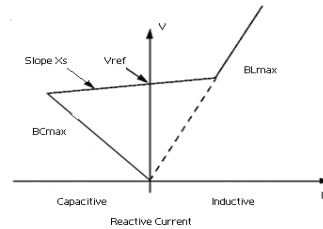

**Figure 1 The V-I Characteristics of SVC**

The SVC can be operated in two different modes:

1. In voltage regulation mode.
2. In var control mode (the SVC susceptance is kept constant).

When the SVC is operated in voltage regulation mode, it implements the V-I characteristic shown in Fig. 1. As long as the SVC susceptance  $B$  stays within the maximum and minimum susceptance values imposed by the total reactive power of capacitor banks ( $B_{Cmax}$ ) and reactor banks ( $B_{Lmax}$ ), the voltage is regulated at the reference voltage  $V_{ref}$ [7]. However a voltage droop is normally used usually between 1% and 4% at maximum reactive power output). The V-I characteristic is described by the following three equations

$$V = V_{ref} + X_s \cdot I \tag{1}$$

SVC is in regulation range ( $-B_{max} < B < B_{Lmax}$ )

$$V = -I / B_{Cmax} \tag{2}$$

SVC is fully capacitive ( $B = B_{Cmax}$ )

$$V = I / B_{LMAX} \tag{3}$$

SVC is fully inductive ( $B = B_{Lmax}$ )

Where,

$V$  = Positive sequence voltage (p.u.)

$I$  = Reactive current (p.u./ $P_{base}$ ) ( $I > 0$  indicates an inductive current)

$X_s$  = Slope or droop reactance (p.u./ $P_{base}$ )

$B_{Cmax}$  = Maximum capacitive susceptance (p.u./ $P_{baae}$ ) with all TSCs in service, no TSR or TCR

$B_{Lmax}$  = Maximum inductive susceptance (p.u./ $P_{base}$ ) with all TSRs in service or TCRs at full conduction, no TSC

$P_{base}$  = Three-phase base power

**STATIC SYNCHRONOUS COMPENSATOR (STATCOM)**

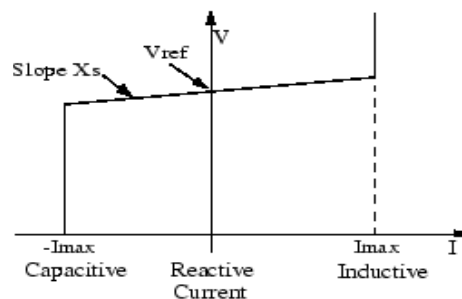

**Figure 2: V-I characteristics of STATCOM**

As long as the reactive current stays within the minimum and maximum current values (-Imax, Imax) imposed by the converter rating, the voltage is regulated at the reference voltage Vref. However, a voltage droop is normally used (usually between 1% and 4% at maximum reactive power output), and the V-I characteristic has the slope indicated in the figure. In the voltage regulation mode, the V-I characteristic is described by the following equation:

$$V = V_{ref} + X_s I \tag{4}$$

Where

V : Positive Sequence Voltage (pu)

I : Reactive Current (I>0 indicates an Inductive Current)

Xs: Slope or Droop Reactance

### SIMULATION AND RESULTS

The investigated power system network is modeled and simulated in MATLAB / SIMULINK as shown in Fig. 3 and Fig. 4 to study the steady state behavior with SVC and STATCOM . The fault is initiated between 10 and 10.1 sec from starting of the simulation. The purpose of running simulation in this mode is to verify the dynamic reactive power compensation capability of SVC and STATCOM during the event of fault, while integrating wind power in a distribution network. The network consists of a 132 kV, 50 Hz, grid supply point, feeding a 33 kV distribution system through 132/33 kV, 62.5 MVA step down transformer. There are two loads in the system; one load of 20 MW and another load of 4 MW at 50 km from the transformer. The 33 kV, 50 km long line is modeled as line. A 9 MW wind farm consisting of six 1.5 MW wind turbines is to be connected to the 33 kV distribution network at 4 MW load point. Dynamic compensation of reactive power is provided by a SVC or STATCOM located at the point of wind farm connection. The 9 MW wind farm have conventional wind turbine systems consisting of squirrel-cage induction generators and variable pitch wind turbines. In order to limit the generator output power at its nominal value, the pitch angle is controlled for winds exceeding the nominal speed of 9 m/s. Each wind turbine has a protection system monitoring voltage, current and machine speed. Test system is simulated in MATLAB/Simulink. Fig.3 and Fig. 4. shows the Simulink model of the test system. Phasor simulation is used to simulate the test system; so as to make it valid for intended purpose. Variable-step ode23tb solver is used for simulation. The simulation time is 15 sec.

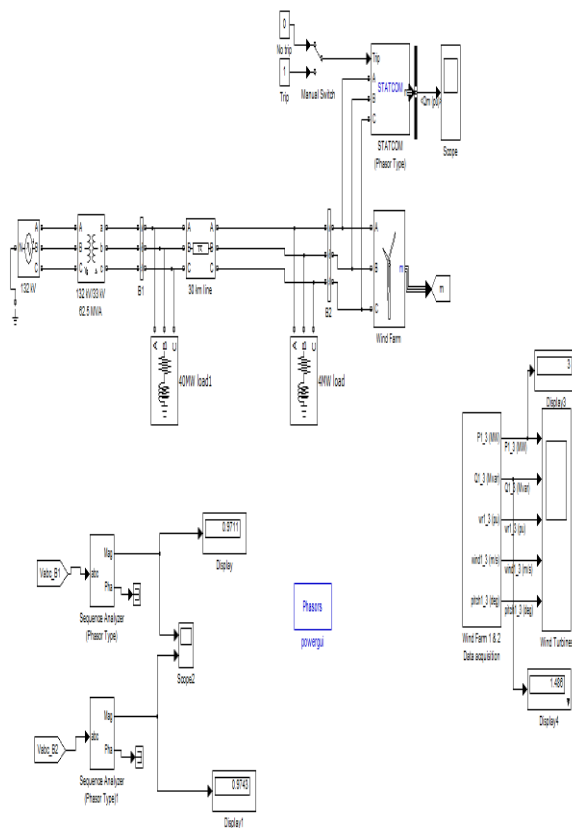

Figure 3: Simulink model of wind farm with STATCOM

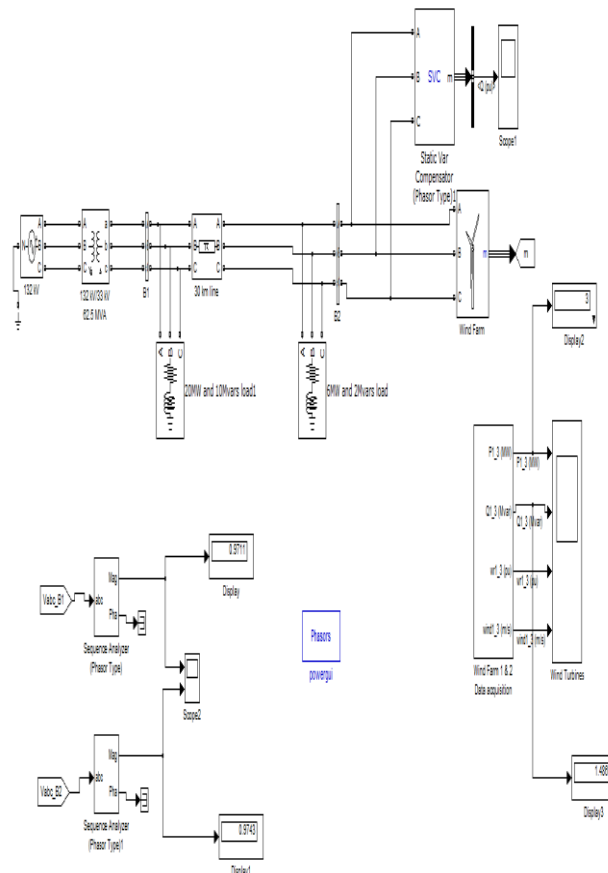

Figure 4: simulink model of wind farm with SVC

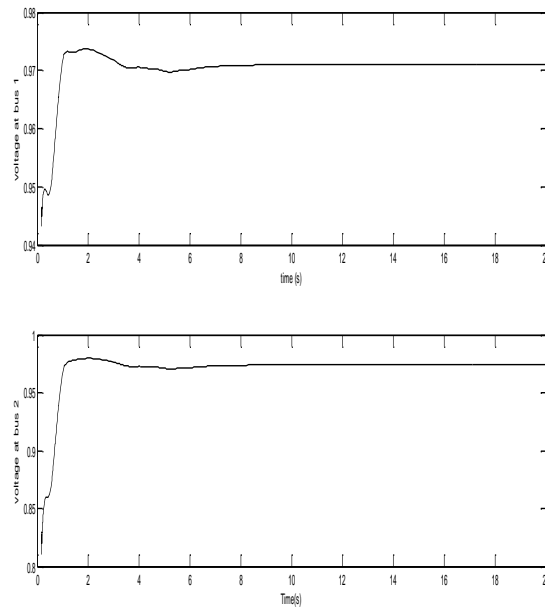

Figure 5 voltage at Bus 1 and Bus 2 with STATCOM

Effect of STATCOM on the system voltage at bus 1 and bus 2 . Results shows that initially fluctuation in voltages is more compared to SVC.

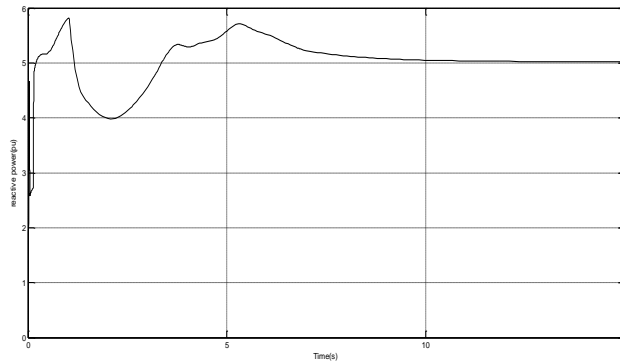

Figure 6 Reactive power of STATCOM

STATCOM used in the simulation 6MVA and rective power is -0.835.

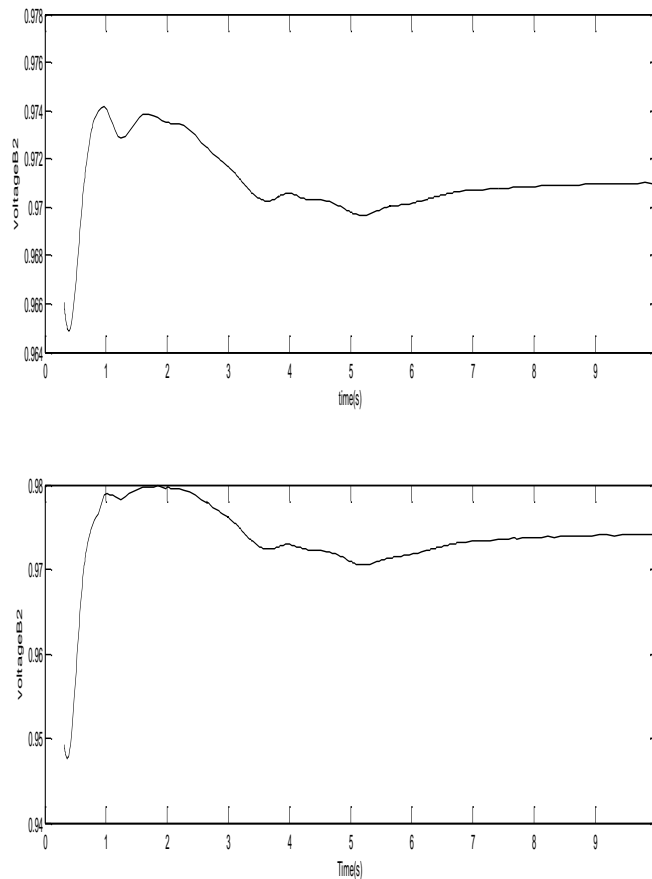
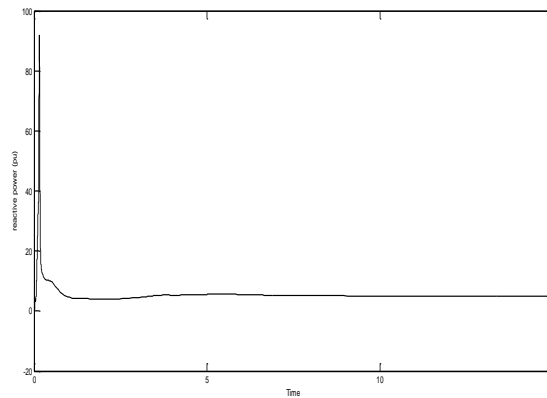

Figure7: Voltage at Bus 1 and Bus 2 with SVC



*Figure8: Reactive power of SVC*

SVC used in the simulation 6MVA and rective power is -0.838

## CONCLUSION

Voltage instability problems occur in a power system that is not able to meet the reactive power demand during faults and heavy loading conditions. Dynamic compensation of reactive power is an effective measure of preserving power quality and voltage stability. When a wind farm is connected to a weak power grid, it is necessary to provide efficient power and voltage control during normal operating conditions and enhanced support during load changes. FACTS devices find application in Wind Farm consists of SCIG that operate at fixed wind speed connected to a Grid system. There is need to study the system during different loads condition and check the effect of FACTS devices such as STATCOM and SVC. An appropriately rating FACTS device can provide the necessary reactive power compensation when connected to a weak grid. Also, a higher rating STATCOM can be used for efficient voltage control and improved reliability in grid connected wind farm but its rating is limited due to economic. Simulation studies have shown that the additional voltage/var support provided by an external device such as a STATCOM and SVC can significantly improve the wind turbine's disturbances recovery by more quickly restoring voltage characteristics. The response of a wind farm to sudden load changes is improved by the use of a STATCOM and SVC in the system.

## REFERENCE

- [1] S. A. Awad, M. M. A. Salama, Fellow, and Ramadan El Shatshat, "STATCOM modeling Impact on Wind Turbines Low Voltage Ride Through Capability".
- [2] L. Huchel, Mohamed hawky El Moursi, and H. H. Zeineldin, "A Parallel Capacitor Control Strategy for Enhanced FRT Capability of DFIG", IEEE TRANSACTIONS ON SUSTAINABLE ENERGY, VOL. 6, NO. 2, APRIL 2015.
- [3] Omar AL-Masari and Musa AL-Masari, "Influence of a Wind Farm on Power System Oscillatory Stability", International Journal of Inventive Engineering and Sciences (IJIES) ISSN: 2319-9598, Volume-2 Issue-9, August 2014.
- [4] Naimul Hasan, Ibraheem, and Shuaib Farooq, "Dynamic Performance Analysis of DFIG based Wind Farm with STATCOM and SVC", International Journal of Emerging Technology and Advanced Engineering, Volume 2, Issue 7, July 2012.
- [5] Dao Zhou, Frede Blaabjerg, Mogens Lau, and Michael Tønnes, "Optimized Reactive Power Flow of DFIG Power Converters for Better Reliability Performance Considering Grid Codes", IEEE TRANSACTIONS ON INDUSTRIAL ELECTRONICS, VOL. 62, NO. 3, MARCH 2015.
- [6] Yuvaraj and Dr.S.N.Deepa, "Improving Grid Power Quality With FACTS Device on Integration of Wind Energy System", STUDENT PULSE, APRIL 2011, VOL. 3, ISSUE 4.
- [7] Marta Molinas, Jon Are Suul, and Tore Undeland, "Low Voltage Ride Through of Wind Farms With Cage Generators: STATCOM Versus SVC", IEEE TRANSACTIONS ON POWER ELECTRONICS, VOL. 23, NO. 3, MAY 2008.
- [8] Wenyong Guo, Liye Xiao, Shaotao Dai, Yuanhe Li, Xi Xu, Weiwei Zhou, and Luo Li, "LVRT Capability Enhancement of DFIG With Switch-Type Fault Current Limiter", IEEE TRANSACTIONS ON INDUSTRIAL ELECTRONICS, VOL. 62, NO. 1, JANUARY 2015.

- [9] Ganesh Barve, "Application Study of FACTS Devices in Indian Power System ", IJCAT - International Journal of Computing and Technology Volume 1, Issue 1, February 2014.
- [10] A. S. A. Awad, Ramadan El Shatshat, and M. M. A. Salama, "Low Voltage Ride Through Capability Enhancement of Wind Farms' Generators: DVR Versus STATCOM"
- [11] Miad Mohaghegh, Montazeri, and David Xu, "Coordination of DFIG and STATCOM in a Power System".
- [12] Mustafa Jawad Kadhim, and D.S.Chavan, "Stability Analysis of DFIG-based Wind Farms Using Different Bus Systems", International Journal of Innovative Technology and Exploring Engineering (IJITEE) ISSN: 2278-3075, Volume-2, Issue-4, March 2013.

## APPENDIX

System voltage: 33 kV

System frequency: 60 Hz

SCIG-

Rated power (MW): 3

Rated voltage (V): 575

Rated frequency (Hz): 60

Stator resistance (pu): 0.004843

Rotor resistance (pu): 0.004377

Stator leakage inductance (pu): 0.1248

Rotor leakage inductance (pu): 0.1791

Mutual inductance: 6.77

STATCOM-

Rating: 6MVA

System nominal voltage: 33KV

Frequency: 60Hz

SVC-

Rating: 6MVA

System nominal voltage: 33KV

Frequency: 60Hz

Rating: 30 MVA

Load 1-

Active power: 20 MW

Reactive power: 10 MVAR

Load 2-

Active power: 6MW

Reactive power: 2MVAR